

No. D.21016/03/2020-21 (Stores)
GOVERNMENT OF INDIA
MH&FW., DGHS
BCG VACCINE LABORATORY
 No.110, 33 FEET ROAD,
 MOUNT ROAD, GUINDY,
 CHENNAI – 600032. TAMILNADU

The following checklist portion should be filled in by the tenderer and submitted along with the tender: (Tick Yes or No)

1	Whether Tender forms for supply of Bifid Siliconised Rubber Wads 13MM Bromo Butyl Lyo, Grey Colour Suitable for 2R Vials - Ready to wash, duly filled and signed in all pages?	Yes / No
2	Whether the rates quoted are on F.O.R (Free On Road) basis including Unloading Charges at BCG Vaccine Laboratory, Guindy, Chennai – 32?	Yes / No
3	Whether the firm is in the approved list of any Government organization? If so proof of the same to be enclosed.	Yes / No
4	Whether the GeM Seller ID is provided? if not, the firm should register with GeM and provide GeM Seller ID for award of contract / placement of order.	Yes / No
5	Do you agree to all the terms and conditions stipulated in the tender by the Director, BCG Vaccine Laboratory, Guindy, Chennai-600032 including delivery, penalty etc. in this connection?	Yes / No
6	Whether EMD enclosed? If No, reason for the same to be given	Yes / No
7	Whether Vendor Qualification Form duly filled and enclosed?	Yes / No
8	Whether required sample submitted?	Yes / No
9	Whether the firm is having cGMP certificate? if yes, proof of the same to be enclosed.	Yes / No

Signature of Tenderer with Official stamp

Name (in block letter):

Address:

GOVERNMENT OF INDIA
MH&FW., DGHS
BCG VACCINE LABORATORY
No.110, 33 FEET ROAD,
MOUNT ROAD, GUINDY,
CHENNAI – 600032. TAMILNADU

TERMS AND CONDITIONS in respect of Tender No. D.21016/03/2020-21 (stores) due on 17.11.2020 for supply of Bifid Siliconised Rubber Wads 13MM Bromo Butyl Lyo, Grey Colour Suitable for 2R Vials - Ready to wash, to BCGVL, Guindy, Chennai – 600032.

1. The duly filled and signed Tender Forms should be submitted to the Director, BCG Vaccine Laboratory, Guindy, Chennai - 32 on or before 17.11.2020 01:30 PM in sealed cover superscribed on left hand corner end as "For supply of Bifid Siliconised Rubber Wads 13MM Bromo Butyl Lyo, Grey Colour". The Technical Bid will be opened at 03:00 PM on 17.11.2020 in the presence of the tenderer or their nominees present on the day of opening.
2. The tender forms should be filled in legibly or typewritten giving full address of the tenderers. The tenderers should quote in figures as well as in words the rates and the amount tendered by him/them. Alterations and overwritings, unless legibly attested by the tenderer shall disqualify the tenderer himself /themselves of his/their authorised agent on his/their behalf. The forwarding letter duly signed should invariably be returned along with the quotations furnished.
3. Since the Vendors have to be qualified by BCGVL, the Vendor Forms enclosed with the Tender forms should be duly filled and submitted along with the Tender.
4. Tenders submitted by persons / firms / organisations who have been disqualified earlier by this Laboratory for any reason whatsoever including delayed supply or supply of sub-standard materials, are liable to be rejected.
5. Successful Tenderer should provide GeM Seller ID for award of contract / placement of order.
6. The Tenderer shall clearly state on each schedule whether he/they are the direct Manufacturer or Supplier or accredited agent/sole representative of their Principals (indicating the name and address of the manufacturers i.e their Principals)

.....3...

A

7. The Tenderers should clearly specify the rates in figures and in words in such a manner that no interpolation is possible. No Columns should be left blank, which would otherwise make the tender liable for rejection.
8. The total rate should be inclusive of all Taxes and Levies, Packing, Forwarding and Insurance etc. as per the format enclosed in the Tender Form as **Annexure-III**. Tenders not conforming to these requirements are liable for rejection and no correspondence thereof will be entertained on whatsoever circumstances.
9. The tenders should be submitted in two covers. Technical Bid and Financial Bid should be sealed by the Bidder in separate covers duly superscribed and both these sealed covers are to be put in a bigger cover which should also be sealed and duly superscribed.
10. Guaranteed delivery with definite date of delivery at destination taking into cognizance transit facilities must be indicated.
11. Sales tax clearance certificate and Income Tax clearance Certificate shall be enclosed to the Tender.
12. Sample should be supplied along with the tender as free samples for trial, which should qualify our quality control test. Minimum requirement of sample is 3000 Nos. The samples will be checked for complying the technical specification and machine suitability. The company which qualifies the technical specification and satisfy the quality only will be considered for Financial Bid opening.
13. The item which does not comply with the specification shall be rejected. No payment will be made for rejected materials. The tenders will not be entitled to any monetary claim or compensation for such materials. Rejected materials should be removed and replaced by the Tenderer at their own cost within 2 weeks of the date of rejection. In case these are not removed, the same will be auctioned at the risk and responsibility of the supplier without any further notice.
14. In case of replacement, the Vendor should supply the replacement of the goods first and then take the rejected materials.
15. The tender will be finalized only after trial and approval of the samples. If the samples are not received along with the tender within the stipulated time, the tender is liable to rejection.

16. The completed tender forms shall be submitted alongwith Earnest Money Deposit of **Rs.30,000/-** by Demand Draft drawn in favour of "the Pay and Accounts Officer, Ministry of Health & Family Welfare, Government of India, Chennai – 90". Tenders received without Earnest Money Deposit will summarily be rejected.
17. The successful tenderer will be required to deposit an amount equal to 10% of the total value of the tendered quantity in one lumpsum as Security Deposit by means of Demand Draft in favour of "the Pay and Accounts Officer, Ministry of Health and Family Welfare, Chennai – 90" or shall produce a bank guarantee for the similar amount in the name of "the Director, BCG Vaccine Laboratory, Guindy, Chennai – 32". Bank Guarantee should remain valid for a period of sixty days beyond the date of completion of all contractual obligations of the supplier including warranty obligations.
18. The requirement of store indicated in the quotation form is approximate only. The figure is subject to change without notice.
19. The Purchaser reserves the right to place order on successful tenderer for additional quantity upto 15% of the quantity for which the tender / order has been placed at the rates quoted.
20. The Purchaser reserves the right to negotiate the price with the second and / or the third least bidder and distribute the supply order equally to a maximum of three suppliers who may be willing to supply materials at the rates offered by the least bidder.
21. This Laboratory reserves the right to modify the quantity of the materials indicated in the tender notice depending upon its requirement. The goods will be supplied against specific supply order to be placed by this Laboratory from time to time as per approved sample within the stipulated time of delivery. It is not compulsory that the tendered quantity should be ordered to the supplier.
22. This Laboratory reserves the right to cancel the supply order at any time without further notice, in case the supplies are not effected within the stipulated period. The materials received after cancellation of the supply order will be liable for rejection at the risk and cost of the supplier.

...5...



23. 'Force Majure' will be accepted on adequate proof thereof. Any condition, which may arise enabling the invocation of this 'Force Majure' clause should be informed to the Laboratory in writing by the supplier within 15 days of the happening (of floods, fire etc..) in order to claim any benefit under this clause.
24. In case of inability to honour this contract due to unforeseen circumstances, this office shall be informed sufficiently in advance, **say three months**, for observing formalities and for making alternate arrangement to avoid inconveniences. In such an event any extra expenditure incurred shall be made good by the supplier.
25. If the supply is not carried out within the stipulated delivery period, a penalty of 2% of the total value of the store ordered for supply will be imposed for every 7 days delay and fraction thereof.
26. The Director, BCG Vaccine Laboratory, Guindy, Chennai would be the final authority to accept or reject full or part of the supply which is in contravention of the terms and condition.
27. Each and Every page of the tender form should be signed by the tenderer with stamp.
28. It would be assumed that the tenderers submitting tenders have considered and accepted all the terms and conditions before submitting the tender forms to BCGVL, Chennai. No enquiries, verbal or written shall be entertained in respect of acceptance and rejection of tender.
29. Any act on the part of the tenderer to influence anybody in this Institution shall disqualify the tenderer from submission of the tender.
30. The refund of Security Deposit will be made after completion of the supply satisfactorily. If supplier fails to supply the total quantity the Security Deposit will be liable to be forfeited.
31. The Director, BCG Vaccine Laboratory reserves the right to reject/cancel the tender, without assigning any reason.
32. The supplies shall be made strictly in accordance with quality of samples approved.

33. For the supplies made Certificate of Analysis or any relevant certificate should be submitted for every batch.

34. For the supplies made, two copies of delivery challan shall be presented to the officer-in-charge who will check and sign on both the copies of the Challan and return one copy which shall be attached with the bill of the vendor.

35. The firms/suppliers should give a certificate that the rates offered/quoted by them are fair enough and that the articles of stores quoted were not and will not be sold by them at cheaper than the rate quoted in the open market.

36. Preference will be given to the manufacturer having cGMP Certificate.

37. Compliance Report shall be submitted in the format enclosed in the Tender Form as **Annexure - II**

ADMINISTRATIVE OFFICER
FOR DIRECTOR

13mm Yuhkes Stoppel

ALL DIMENSIONS ARE IN MM

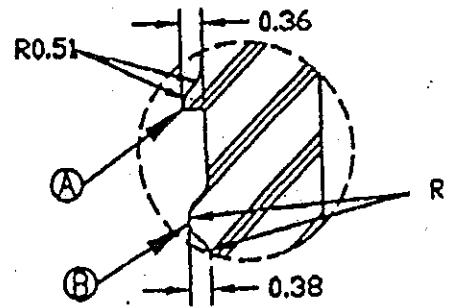
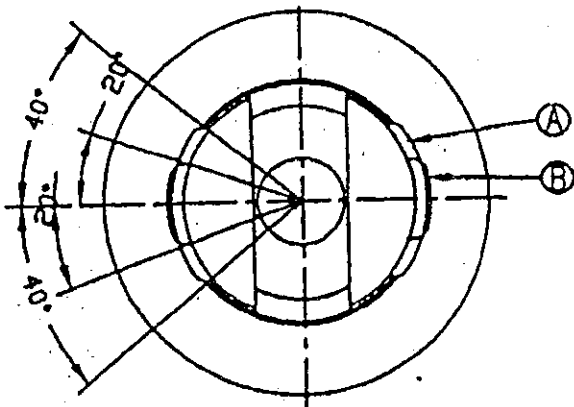
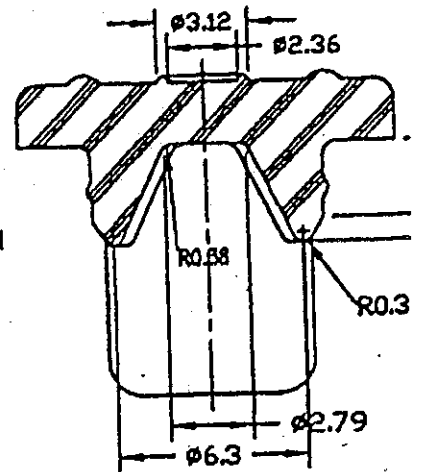
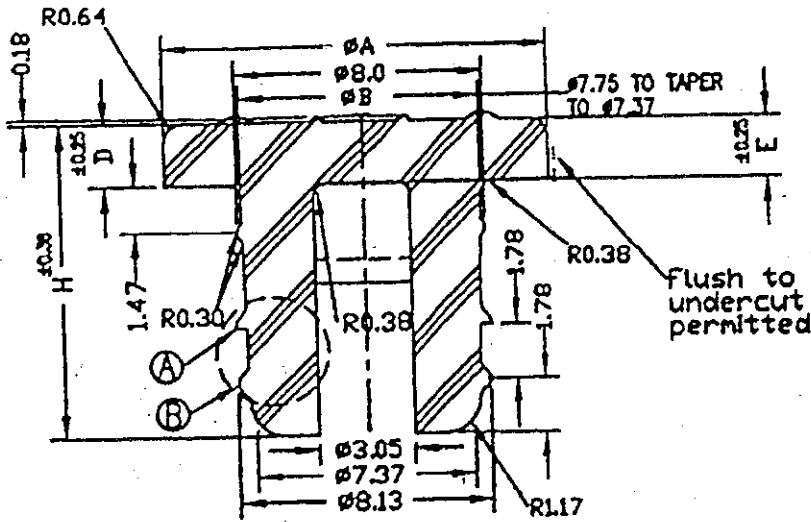
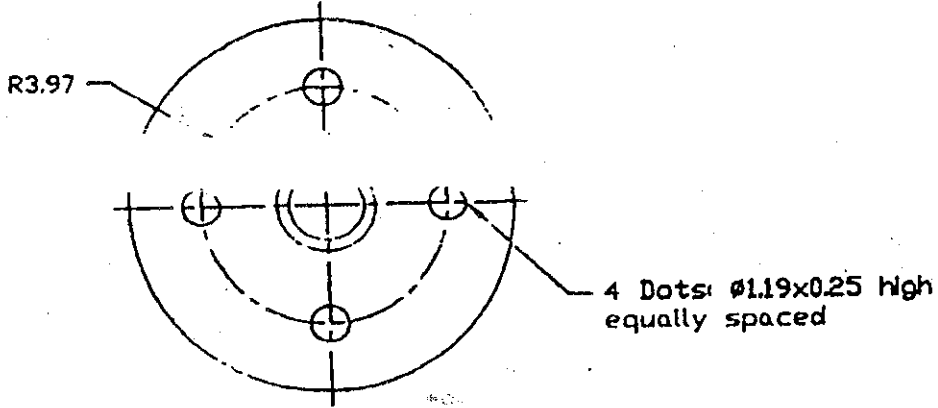

STANDARD DIMENSIONS

12.45	7.75	1.98	1.98	10.16
± 0.25	± 0.25	± 0.25	± 0.25	± 0.38
A	B	D	E	H

Handwritten signature

Handwritten signature
TS - Containment

Handwritten signature
EM8

Handwritten mark

COMPLIANCE REPORT

Sl.No.	Specification as per Tender Document	Vendor Specification	Justification / Remarks

SIGNATURE OF THE TENDERER WITH SEAL

No. D.21016/03/2020-21 (Stores)

Dated:

Sl No	Particulars	Quantity Reqd.	Unit Price in Rs.	Unit Price in words
1	Supply of Bifid Siliconised Rubber Wads 13MM Bromo Butyl Lyo, Grey Colour Suitable for 2R Vials - Ready to wash as per drawing and specification enclosed in the Tender Form as Annexure-I.	10 lakhs (Should be supplied in phases if required)		
2	Taxes and Other charges if any			
		Total		

- The above mentioned requirement will increase or decrease based on the demand from User Section.
- The rates shall be quoted on F.O.R. (Free On Road) basis including Unloading Charges at BCG Vaccine Laboratory, Guindy, Chennai – 600 032.

1. I/We, the undersigned, certify that I/we have gone through the terms and conditions mentioned in the tender document and undertake to comply with them.

2. The rates quoted by me/us are valid and binding upon me/us for the entire period of contract. It is also certified that the item quoted are of standard quality and workmanship.

3. I/We hereby undertake to supply the items as per directions given in the tender document/Purchase Order within the stipulated period.

4. There is no vigilance / CBI case or court case pending against me/us/my firm.

5. This is to declare & certify that the neither myself nor my firm have ever been blacklisted / banned by any Govt. / Semi Govt. / Public / Private Institution.

6. I/We hereby certify that the firm poses all the required license / certification to perform the work.

Date:
Place:

Signature of the Tenderer
Full Name:
Company's Seal: